

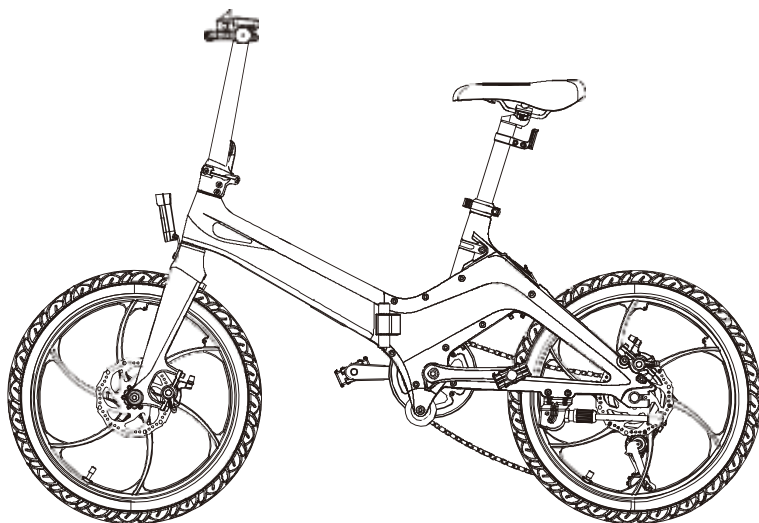

ELECTRIC BIKE



yeep.me TWENTY

Instruction manual

Please read this manual carefully before first use

Original Instructions

Thank you for your purchase.
Welcome to the yeeppers community!

Table of contents

1. SAFETY GUIDELINES	04
2. CONTENTS AND TECHNICAL SPECIFICATIONS	09
3. USE	10
4. MAINTENANCE AND CLEANING	18
5. FAQ & WARRANTY	23

Before using this product, carefully read the user guidelines. These will allow you to properly understand, use and service this product, and to get to know its performances and features.

Keep this manual for future reference. If selling or giving this product to someone else, please ensure you include this manual along with it.

EN 1. SAFETY GUIDELINES

1.This device is designed to transport one person, and is intended for use by teenagers and adults.

Cleaning, maintenance and all other handling of the device must be performed by someone over the age of 12.

This device may be used by children aged 12 and up, and may also be used by persons with physical, sensory or mental disabilities, on condition that adequate supervision is provided or they have been instructed on how to operate the device safely and are aware of any potential risks. Children should not be allowed to play with the device. Cleaning and user maintenance should not be performed by unsupervised children. Parents should not let their child use this device unsupervised. The product should be stored out of the reach of children.

The charger may be used by children aged 8 years or older and by persons with reduced physical, sensory or mental capabilities or without experience or knowledge, if they are properly supervised or if they have been given instructions on how to use the device safely and if the risks involved have been understood. Make sure that only the charger supplied with the product is used.

Do not transport an additional person, children, or goods. Exceeding the weight limit may cause injuries and damage the device. That the user is within the weight limit does not mean they are tall enough to maintain control of the device.

2.This is an individual transportation device. It is therefore not suitable for competitions or extreme sports, and must never be used in a skate park. Do not use the scooter to go up or down stairs, perform jumps, jump over obstacles, or perform tricks or dangerous acts. This device is neither a toy nor a fitness device.

This product has not been designed for professional or commercial use, such as: rentals, forming a fleet of vehicles, business trips.

3.This device should be used with caution on a surface that is flat, clean, dry and free of gravel and grease, as there needs to be friction between the wheels and the ground to move forward. Avoid obstacles, holes, bumps, and

sewer grates that may cause accidents. Slow down for speed bumps.

Stay away from other road users and observe traffic rules. You are not safe from the risks posed by the behaviour of others. Anticipate obstacles and traffic by driving at an appropriate speed. The stopping distance is correlated with your speed, so take care to anticipate braking distances in wet weather and/or on wet roads. Avoid abrupt manoeuvres and sudden braking; the device may skid, lose its balance, or fall, even on a smooth, flat surface. You must always remain vigilant and stay away from pedestrians and other users on public roads or thoroughfares, who may cross without having seen you. **WARNING!** Never use the product outside the areas permitted by regulations.

 4. Caution! This appliance is designed for outdoor use. It is your responsibility to know and comply with the regulations in force on the public and private thoroughfares where you use the device.

5. Learn how to use the device in an open and flat location without many other road users around you, and make sure you wear a helmet. Always wear sturdy shoes and trousers when using this device. Do not operate this device if you are barefoot or wearing open sandals. Avoid wearing clothing that is excessively loose or has dangling cords or ties, scarves, etc., which could be caught in the wheel. This could lead to choking, falling, and/or a collision.

6. Do not ride in rain, snow, puddles, mud, or other wet areas with a water depth of over 2 cm that would allow water to seep into the device. To clean your device, follow the advice in section 4.3.

Do not use this device if visibility is poor. If you are riding at night or in dark weather, we recommend wearing reflective clothing or equipment, such as a high-visibility jacket or armband. In addition to this recommendation, you should refer to the applicable equipment requirements in the location and country of use.

7. Do not use this device under the influence of alcohol or other drugs. For your safety, such use is strictly prohibited.

8. Do not leave the product within the reach of anyone who could start it without the authorisation of the main user or without prior information and

EN knowledge of these safety measures/guidelines and use.

If you lend the device to someone, ensure the other person knows how to use it and explain to them all the safety guidelines. The person you are lending the scooter to must be reminded to follow traffic regulations and to wear protective gear while riding.

To prevent unauthorised use, be sure to remove the key from the ignition between uses, in order to prevent unintentional or intentional misuse.

9. This device must be turned off before being folded and stored away. For instructions on this, please refer to the "User guide" section of this manual.

10.A mobility device is subject to physical constraints depending on its purpose, design and use. Given this, the unit must be inspected before each use and you must double check that all safety features work properly (brakes, lights). The various points of inspection and maintenance to be carried out on your appliance are detailed in section 4.2.

The folding mechanism must be securely locked into its vertical driving position.

If you notice any pieces have come loose, low battery level alerts, flat tyres, excessive wear and tear, strange noises, improper functioning or any other abnormality, stop using the device immediately and seek professional assistance.











11. DO NOT USE THE DEVICE OR CHARGE ITS BATTERY IN THE FOLLOWING CIRCUMSTANCES:

- The product is damaged.
 - The battery is emitting an abnormal smell and heat.
 - Brake controls, or other braking or safety devices (lights) are damaged.
- Discontinue use and do not touch any liquid leaking out of the device. Do not expose the device's battery to excessive heat.

12. The battery must not be replaced by the user. Please contact your retailer or the brand's after-sales service for any device modifications or maintenance.

13. The batteries must be disposed of appropriately. If you are unable to return your product to your retailer, place it in the containers provided for this purpose (see the brand's manual for more information) in order to protect the environment.

14. Any opening of the device or product may modify the safety of the device or product, and the brand does not take responsibility for this. Please note that opening the device will void the warranty of the device or product. Should you nevertheless wish to carry out repairs on your device yourself, the brand does not take any responsibility for the reliability of the repairs and potential damage these may incur. Accidents that may occur as a result of these repairs are not the brand's responsibility. In case of doubt or when in need of assistance, contact an authorised retailer or the brand's customer support.

Pictogram	Meaning
	Always read the user manual carefully.
	An exclamation mark within an equilateral triangle is intended to alert the user to the presence of important operating and maintenance instructions in the device's user manual.
	This device must not come into contact with water. Do not store the device in a damp environment.
	The lightning flash with an arrowhead symbol within an equilateral triangle is intended to alert the user to the presence of "dangerous voltage" within the device that may be of sufficient magnitude to constitute a risk of electric shock.
	This symbol indicates that this device is equipped with a double electrical insulation between the power supply's (dangerous) voltage and the parts that are accessible by the user.
	Caution! Protective equipment including wrist guards, gloves, knee pads, helmet and elbow pads should be worn.
	Electrical and electronic equipment must be sorted and disposed of separately. Do not dispose of electrical and electronic equipment with normal and unsorted household waste, bring it to a recycling centre instead.
	This marking is used on the nameplate to indicate that the equipment operates on direct current only or to identify the corresponding terminals.
	This marking is used to identify the electronic device comprising the transformer and the electronic circuit, which converts electrical energy to one or more output connectors.
	This marking is used to identify the electronic device comprising the transformer and the electronic circuit, which converts electrical energy to one or more output connectors.

2. CONTENTS AND TECHNICAL SPECIFICATIONS

This pack contains:

- yeeep.me TWENTY electric bike
- Tools
- Original mains charger
- Starter keys (2 keys provided)
- User manual
- Warranty manual
- CE declaration
- Warranty card **TO BE KEPT** (it contains the device's serial number and manufacture date, essential information for warranty purposes)

Technical specifications:

Battery :	Lithium-ion 9.6Ah 36V
Charging time :	4h - 5h
Autonomy :	40-60 km max with assistance*
Speed :	25 km/h*
Motor :	250W Nominal 36V
Charger :	Input : 100-240V ~ 2.5A 50-60 Hz Output : 42V ===2A 84 W
Maximum weight supported :	120 kg
Device weight :	19.8 kg
Device dimensions :	1520x570x1050mm
Model reference :	S9
Charger reference :	FY-4202000

* Generally speaking, range and speed are given as an indication. These vary according to the weight of the user and the conditions of use (slope, outside temperature, humidity, speed and motor load). Specifications may change. These speed and range guidelines do not constitute a contractual commitment on the part of the retailer or the CIBOX INTERACTIVE company.

EN 3. USE



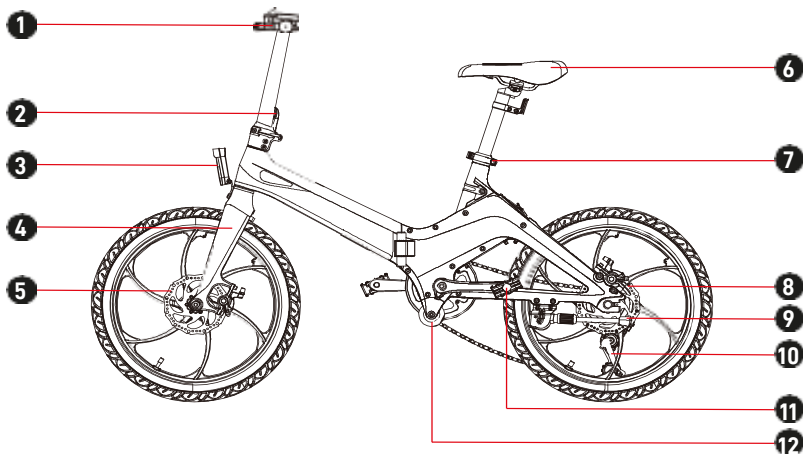

3.1. DEVICE OVERVIEW



(1). Handlebars, brake handles, screen and bell (2). Folding system (3). Front lights (4). Front fork (5). Front brake disc (6). Adjustable saddle (7). Seat height adjustment (8). Rear brake disc (9). Stand (10). Derailleur (11). Pedal with reflector (12). Support wheel.



(1). Battery level % (2). Battery level (3). Button + (4). M button (5). - Button (6). Speed (7). Assistance level (1: 15 km/h; 2: 20 km/h; 3: 25 km/h) (8). Display mode.

M button	Press for 3 seconds to turn the unit on/off. Briefly press to change the display to show TRIP, ODO and TIME.
+ button	Briefly press to increase speed level. Press and hold to turn front headlight on/off.
- button	Short press to decrease speed level.
	Light activation indicator
	Illuminates when braking.
	Throttle grip problem
	Engine trouble indicator
	Controller problem indicator

Assistance modes:

The device has 3 assistance modes. The electric assistance system is activated by 1 to 1.5 turns of the pedals. The higher the mode, the greater the electrical assistance.

Lighting :

The lighting system is a safety equipment of your bike, it must be present on your bike. Check that your lighting system is working and that your batteries are charged before riding.

Doorbell :

A bell is installed on your handlebars. The bell is a safety equipment of your bicycle, it must be obligatorily present on your handlebars.

Brakes :

The right handle activates your rear brake.

The left handle activates the front brake.

EN 3.2. UNPACKING AND ASSEMBLING THE DEVICE

To unpack the product, it is recommended to have a clear surface that is large enough to unpack and prepare the device. Take the device out of its packaging, making sure to not injure yourself or damage other products or your surroundings. Have someone help you if the product is too heavy for you to handle on your own (the weight of the device is indicated on the packaging). An adult must unpack and assemble the device.

Unfold the device:

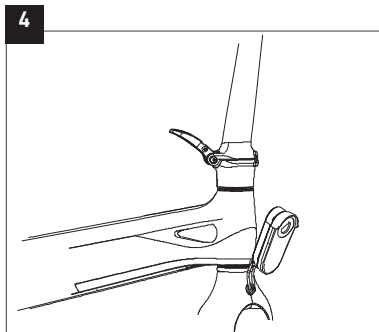
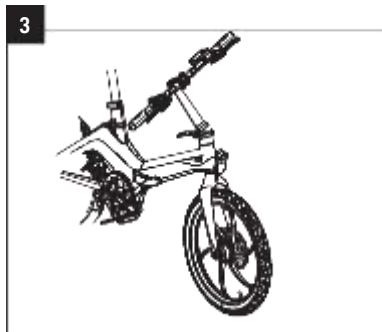
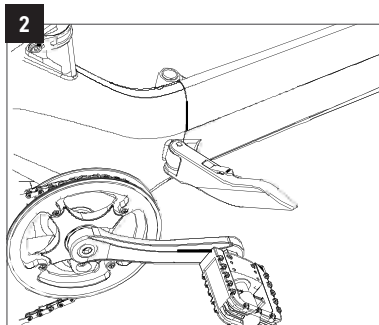
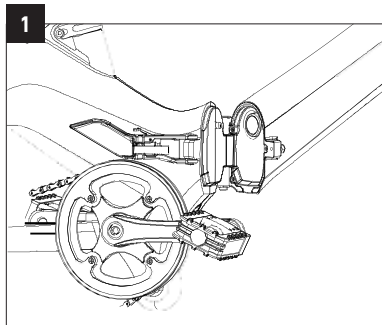

1. Unfold the frame until you can no longer see the location of the battery.
2. Close the frame with the safety lever. Hold the button on the lever and close it until you hear a click.
3. Fold up the handlebar tube.
4. Lock the tube with the safety lever. Push the lever until you hear a click.

Folding and unfolding the pedals :

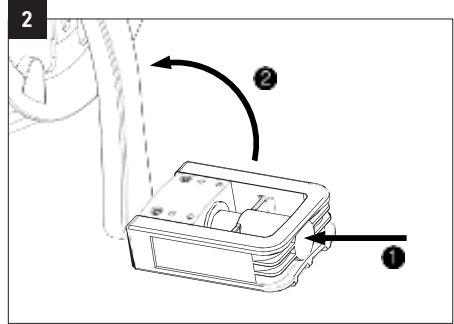
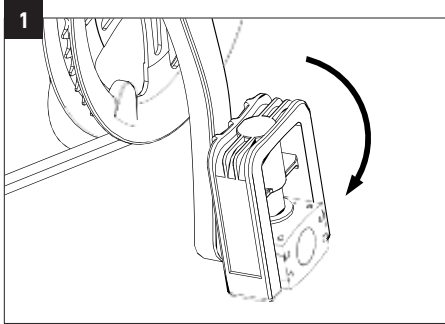

1. To unfold the pedals, lower the pedal as above.
2. To fold the pedals, press inward and then tilt the pedal upward as shown above.

Assembly and adjustment of the saddle:

Loosen the nut on the seat post clamp to be able to change the height of the seat post in the frame.

Select a height and tighten the seat post clamp nut. When adjusting the saddle to its lowest position, make sure that the saddle does not touch any component of the bicycle such as the battery cover. Also, be sure not to exceed the minimum seat tube insertion mark. This insertion mark should never be visible when using the bike.

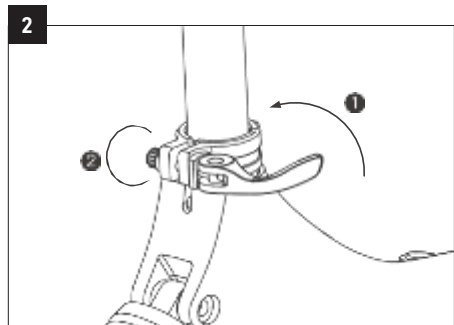
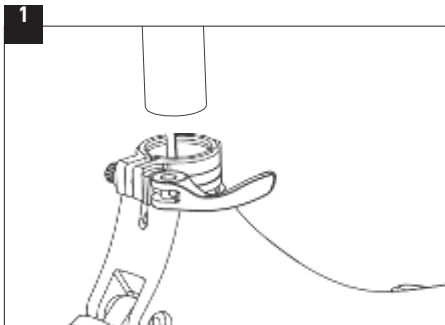

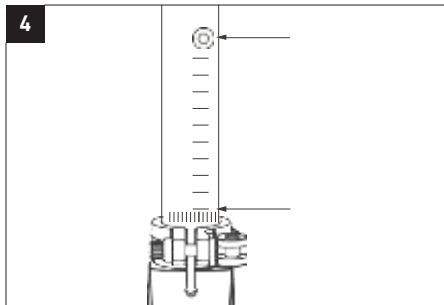
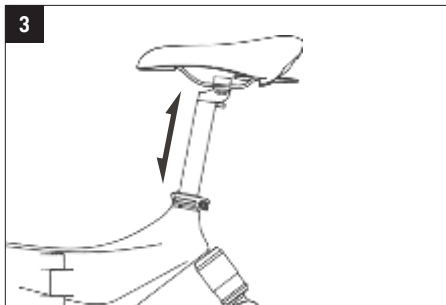

IMPORTANT : To determine your saddle height, sit on the bicycle and place a heel on the pedal in the down position with the crank parallel to the seat post. When your leg is extended the saddle height is correct.

Recommended saddle height and user size:

Wheel dimensions	Maximum height of the saddle	Minimum saddle height	Recommended user size*
20"	90 cm	80 cm	155 - 180 cm

* Size for an «optimal» use of the device.

3.3. CHARGING AND BATTERY INDICATOR

Charge the battery before first use. To do so, charge the device using the charger supplied.



IMPORTANT: Only charge the device with the original charger supplied with the device by the manufacturer. In case of doubt, loss or malfunction, avoid charging the device with another charger. It is advised you obtain a new charger from your dealer. You will find the email address to contact customer support on the last page of the warranty manual.

Next, check the battery charge level before use, using the battery level indicator **(20)**.

There are two ways to recharge the battery:

1. Remove the battery to recharge it.
2. Recharge the battery directly from the battery pack attached to the bike.

In any case, it is advisable to make the connections in the following order:

1. Connect the charger output plug to the battery first, then connect the

charger input plug to the household electrical outlet.

2. Disconnect the input plug from the house power outlet first, then the output plug from the battery.

Note: We recommend recharging the battery after each use and at least once a month. The battery should be recharged indoors.

3.4. PREPARATION

For your own safety, we recommend you use this device in comfortable conditions, wearing protection equipment such as a helmet and appropriate protective gear for your joints (knee pads, elbow pads). For your own safety as well as that of others, drive the scooter wearing closed and preferably flat shoes to ensure you have a good grip and stability.

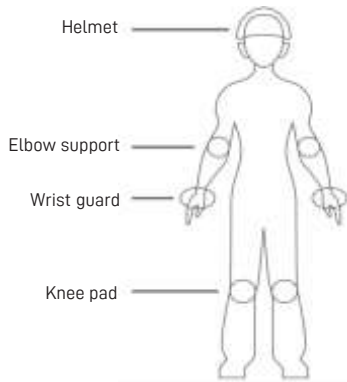

3.5. HOW TO USE THE DEVICE (READ BEFORE FIRST USE)

HELMET WEARING

We strongly advise you to equip yourself before riding the bike with at least one helmet, which must comply with the regulations on personal protective equipment and must be attached.

WARNING: The user must comply with the requirements of national regulations when using the bicycle on public roads, including compliance with the Highway Code.

WARNING: The user is obliged to install lighting, signalling and warning devices on the bicycle.

- It is forbidden to ride on the sidewalk, otherwise the bicycle must be held

in the hand.

- Do not wear earphones or any device that may emit sound, or use a hand-held telephone.

The wearing of a certified retro-reflective vest is mandatory for all cyclists and passengers riding outside the city at night or when visibility is poor. The manufacturer declines all responsibility if the driver of the bicycle does not comply with the regulations in force.

3.6. FIRST USE

Before each use, please check the general condition of your bike.

The good condition of wearing parts such as brakes, tires, steering, transmission, rims, etc. must be checked by the user before every use and regularly checked, serviced and adjusted by a qualified mechanic.

Be sure to properly maintain your bike according to the instructions in the user's manual.

The ideal temperature range for the use of electric bicycles is between 5 and 25°C. Using your electric bicycle in low temperatures, less than 5°C, will not damage your battery but may reduce performance.

The device emits an average sound pressure of less than 70dB at the user's ears.

WARNING: Like any mechanical component, a bicycle is subject to high stress and wear. Different materials and components can react differently to wear and fatigue. If a component has exceeded its service life expectancy, it may break off in a single blow, possibly causing injury to the cyclist. Cracks, scratches, and discoloration in high stress areas indicate that the component has exceeded its life expectancy and should be replaced.

1. Check that the battery is securely in place and locked with the key in the «LOCK» position.
2. Turn on the unit by pressing the ON/OFF button on the control panel.
3. Start pedaling like a regular bicycle.

3.7. HOW TO REMOVE AND REPLACE THE BATTERY

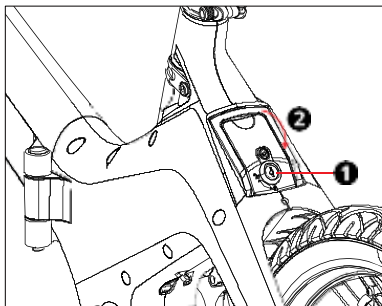

1.To remove the battery, switch off the unit, unlock the battery with the key (1) and remove the battery case by lowering and pulling the handle (2).

2.To replace the battery, place the battery back in its place (with the battery lock facing down), lock the battery with the key and then pull the battery handle all the way up.

3.8. ASSISTANCE, PARKING AND AUTONOMY

Pedaling assistance :

The bike is equipped with an electric pedaling assistance. The motor, located in the hub of the rear wheel, starts once the user starts pedaling and completes his efforts. The operation of the electric assistance depends on the speed of the pedals and the speed of the bicycle. As stipulated by current European legislation, the 250W motor stops at 25 km/h and switches off as soon as the user stops pedaling.

To increase or decrease the power of the motor and therefore of the electric assistance, press the + or - button on the control panel.

Parking :

- Turn off the power by pressing the ON/OFF button on the control panel.
- Lock the battery with the key or remove it and take it with you when the unit is not in use.
- It is advisable to attach the unit when not in use to prevent theft.
- Never park the unit outside when it rains or snows. Prefer a garage that is dry and well ventilated. After a trip in rain or snow, take the unit to a sheltered place and wipe off any moisture with a clean, dry towel.

Mileage/Autonomy :

Many factors affect the rate of electric power usage and range as outlined in Part 4.

In order to maximize the range of your unit, it is important to take note of the following points:

- Fully charge the battery before a long trip.
- The advertised autonomy is measured under optimal conditions of use. User weight, driving speed, rough roads and hilly terrain, tire pressure, headwind, frequent changes in speed and braking (in town) and outside temperature are all factors that affect the range of the device.
- Driving with properly inflated tires and a clean, well-lubricated unit saves energy.
- Regularly check the brake settings and make sure both wheels are moving freely (that the brakes do not rub the wheel while driving).
- Battery capacity decreases as it ages.

9. SPEED LIMITS

The product is designed to travel at a maximum speed of 25 km/h.

Ensure you are following the usage restrictions of this product in terms of the road safety norms of the country where you are using it.

10. DRIVER WEIGHT

The driver's weight cannot exceed 120 kg.

Note: not respecting this weight limit increases the risk of falling or damaging the product.

4. MAINTENANCE AND CLEANING

1. BATTERY

The capacity of lithium batteries decreases after several charging and re-charging cycles throughout its lifespan. The concept of life cycle exists for lithium batteries (for example, about 300 on a scooter). This means that from 300 COMPLETE cycles of charges and discharges, the battery will begin to lose its capacity (similar to a smartphone battery).

This partial loss of capacity will not prevent the battery from functioning, but will alter its performances and especially its operating life.

The device must be used and its battery recharged at least once a month: a lithium battery will lose its charge even when the product is off. This is why a

battery that has not been charged for several weeks or less could lose some of its capacity and become impossible to recharge.

In addition, it is possible to recharge a lithium battery after each use because there is no memory effect.

WARNING: charging the battery must only be done indoors or in a place that is protected from weather (rain, snow, excessive heat...)

In order to better preserve your device's battery, here are some reminders and instructions for use:

- Do not unplug the charger before the battery is fully charged.
- Store the product containing the battery in a cool place (temperature > 0°C), preferably around 15°C. Be careful, as excessive heat will also damage the battery.
- Avoid deep discharges.
- Avoid recharging the battery right after use. Allow the device to rest for between 15 minutes and 1 hour after use before charging.
- Avoid overloads. Do not leave the charger plugged in for more than 24 hours, as it will heat up needlessly.

Notice: We recommend recharging the battery, if not in use, after each use and at least once a month.

Important: If you are not near a charging point when the battery is down to its last quarter, we recommend switching to eco mode.

Tip: As you drive, the battery level indicator on the display may suddenly decrease depending on your driving style and conditions (heavy use of the accelerator, riding uphill, outside temperature below 10°C, etc.). Be aware that the actual battery level displayed will be most accurate when the device is turned off.

4.2. INSPECTING AND MAINTAINING YOUR DEVICE

Your product requires routine inspection and maintenance. This chapter describes maintenance and operation steps. Before performing the following operations, make sure that the power is off and that the charging cable is unplugged. Before each use, carefully check:

- The tightness of the handles.
- That the wheels are functioning properly by lifting the device and running the wheels idle.
- The column, the steering tube, nothing must prevent it from turning. The entire steering system must be correctly adjusted and all connecting

elements and screws tightened and in good condition.

- Check the tightness of the screws, the front and rear wheels, shock absorbers, and bonnet, and tighten again if necessary. These adjustments may be needed because of vibrations caused by using the device.
- The condition of the tyres. Tyre pressure if the unit is equipped with air wheels, and inflate as soon as is necessary using a bicycle pump or similar.
- The brakes, drum linings, brake pads, foot brake, depending on the unit. If the unit is equipped with mechanical brakes (disc, drum, foot), ensure they are not rubbing due to cable tension or exhibiting any other problems, as this may cause the unit to slow down and prevent it from operating normally. Overheating may impact the brake's efficiency.
- Check that the electric brake is functioning properly if the unit is equipped with one.

If after adjusting you notice looseness that may affect your ability to drive safely, or if an unusual noise appears, or a lack of fluidity is apparent, stop using the unit and contact your dealer for more information or care.

If the product, a component, or the battery are worn out, please contact an authorised service centre to repair or recycle your product.

MAINTENANCE AND SPARE PARTS :

Your bike requires regular maintenance for your safety but also to increase its life span. It is important to check the mechanical components periodically to ensure that worn or worn parts are replaced if necessary.

The battery must be removed before each maintenance operation.

WARNING: When replacing components it is important to use original parts to maintain the performance and reliability of the bicycle. Only manufacturer's parts are considered original parts.

WARNING: It is the responsibility of the user in case of purchase and use of fake (counterfeit) parts that subsequently cause damage to the product, person or environment.

Make sure to use appropriate spare parts for tires, inner tubes, transmission elements and various components of the braking system. If you have any questions, please contact the service department or your dealer.

The manufacturer cannot be held responsible for improper use or incorrect installation.

WARNING 1 : Like all mechanical components, EPAC is subject to wear and high stress. Different materials and components can react to wear or stress fatigue in different ways. If a component's rated life has been

exceeded, it may fail suddenly, resulting in injury to the operator. Any form of cracking, scratching, or color change in the high stress areas indicates that the life of the component has been reached and must be replaced.

WARNING 2: For composite components, impact damage may be invisible to the user, the manufacturer must explain the consequences of impact damage and that in case of impact, composite components must either be returned to the manufacturer for inspection or destroyed and replaced.

LUBRICATION

Lubrication is essential on the various components that are in motion to prevent corrosion. Oil the chain regularly, brush the sprockets and chainrings, periodically introduce a few drops of oil into the brake and derailleur cable housings.

It is advisable to first clean and dry the components to be lubricated. It is advisable to use oil specifically for the chain and derailleur. Grease should be used for the other components.

PNEUMATICS

It is strongly recommended to check tire pressure periodically. Driving with under-inflated or over-inflated tires can impair performance, cause premature wear, cause rim damage, reduce range or increase the risk of accidents. If severe wear or a notch is visible on any tire, replace it before riding the bicycle.

IMPORTANT : A pressure range is indicated on the sidewall of the tire by the manufacturer. The pressure must be adjusted according to the user's weight.

BRAKES

Before each use, check that the front and rear brakes are in perfect working order. Check the brakes regularly to prevent accidents due to brake malfunction.

The brake lever must not come into contact with the handlebars and the sheaths must not be at a closed angle so that the cables slide with the minimum of friction. Damaged, frayed, rusted cables must be changed immediately.

WARNING: In rain or wet weather the braking distances are extended.

EN RIMS

Check the condition of the rim and clean it if it is dirty to avoid premature deterioration. Do not ride with a damaged or cracked rim that could cause an accident.

CABLES

Make sure that the cable ports are not loose or broken.

SCREW

Check the screws in the main parts, and make sure to tighten them regularly. Vibrations of the unit while driving cause vibrations that loosen the screws.

BATTERY

For your safety and to optimize battery operation, always store the battery in a dry, well-ventilated area away from moisture. It must not be subjected to blows or have faulty wiring.

WARNING: Use only the battery supplied. Do not use or charge non-rechargeable batteries.

CHARGER

Make sure that the charger cord is not damaged or that the wires are exposed to avoid short circuits. The input and output sockets must not be damaged or deformed.

WARNING: Be sure to use only the charger supplied with the product.

LUGGAGE RACK

If your bike is sold with a luggage rack. It is already fixed above your rear wheel. Fasteners should be tightened and checked frequently.

Your luggage carrier is designed for a maximum load not to exceed 25kg. It is possible to attach a child seat.

When using a spring loaded saddle, these must be protected to prevent finger entrapment. Your luggage carrier is not designed to tow a trailer.

For safety reasons, luggage should only be transported on the luggage carrier. When the luggage rack is loaded, the behavior of your bicycle may change. Luggage must not obscure the reflectors and lights of your bicycle.

Distribute the luggage load evenly to promote the stability of your bicycle. All luggage must be securely fastened to the luggage rack, before each use it is important to check that nothing can get caught in the rear wheel of the bicycle.

Do not adjust the luggage rack arbitrarily, please ask your dealer for advice on

how to adjust it if necessary. Do not modify the luggage rack, any modification of the luggage rack by the user will invalidate these instructions.

Warnings about the risks associated with incorrect assembly or adjustment of the various components of the bicycle:

Failure to follow these instructions may result in improper use of your bike, premature wear of certain components that may lead to a fall and/or accident.

4.3. CLEANING YOUR DEVICE

Follow these instructions and precautions for cleaning the device:

- Unplug all the device's charging cables before cleaning it.
- Never immerse in water.
- Do not use a high-pressure cleaner, water jet or any other appliance or washing method that would allow water to seep into the device.
- Clean the device with a slightly damp sponge or a soft cloth, avoiding the connectors and buttons and making sure water is not allowed to seep into the plugs, circuits or inside the product.
- Do not use water or liquid cleaners directly on the device to clean it.
- Do not use abrasive products or solvents as these could damage the paint on your device.
- Be careful when cleaning and wiping plastic parts.
- Do not use abrasive products or solvents to clean metal or plastic parts.

4.4. STORING YOUR DEVICE

- Fully charge your device before storing it.
- Store your product indoors in a clean and dry place with an ambient temperature ranging from 0°C to 40°C.

5. FAQ & WARRANTY

1. FAQ

If your device cannot be unlocked:

Check that the unlock button can be moved and is not damaged. Check that the entire mechanism is clean before attempting to fold/unfold the device again. If the problem persists, please contact an authorised service centre for repairs.

Your device does not turn on

Check that the ON/OFF button is not damaged and recharge your device before trying again.

Your device cannot be recharged

Check that the connections of the product and the original charger are not damaged.

In order to identify whether the charger or the device is faulty, check that the charge indicator on the charger is on. When the charger is connected to the mains and to the product, the indicator will be:

- **RED** (indicates that the device is charging)
- **GREEN:** indicates that the device is fully charged.
- **RED-GREEN:** flashing alternatively. This happens when the battery is very low. Wait 15 minutes while staying nearby. If the indicator turns red, the device is now charging normally.

If the indicator keeps flashing, that means there is an issue with the charger or the product (battery, connector...).

If the problem persists, please contact an authorised service centre for repairs.

If the device is not running smoothly:

This can happen when you overload the engine while the battery is not fully charged. In such a case, it is necessary to press the accelerator more slowly and especially to check that the battery is fully charged.

5.2. WARRANTY

For information on warranty conditions and limitations of liability, please refer to the warranty manual provided, or consult it online using the QR code found on the last page or by entering the following address: **download.yeep.me**



yeep.me TWENTY

CIBOX INTERACTIVE
17 allée Jean Baptiste preux
94140 ALFORTVILLE
France

Made in Poland



YEEP025-032021-V1-A